

CINDERELLA FREEDOM

MODEL PM02CS03

Product manual

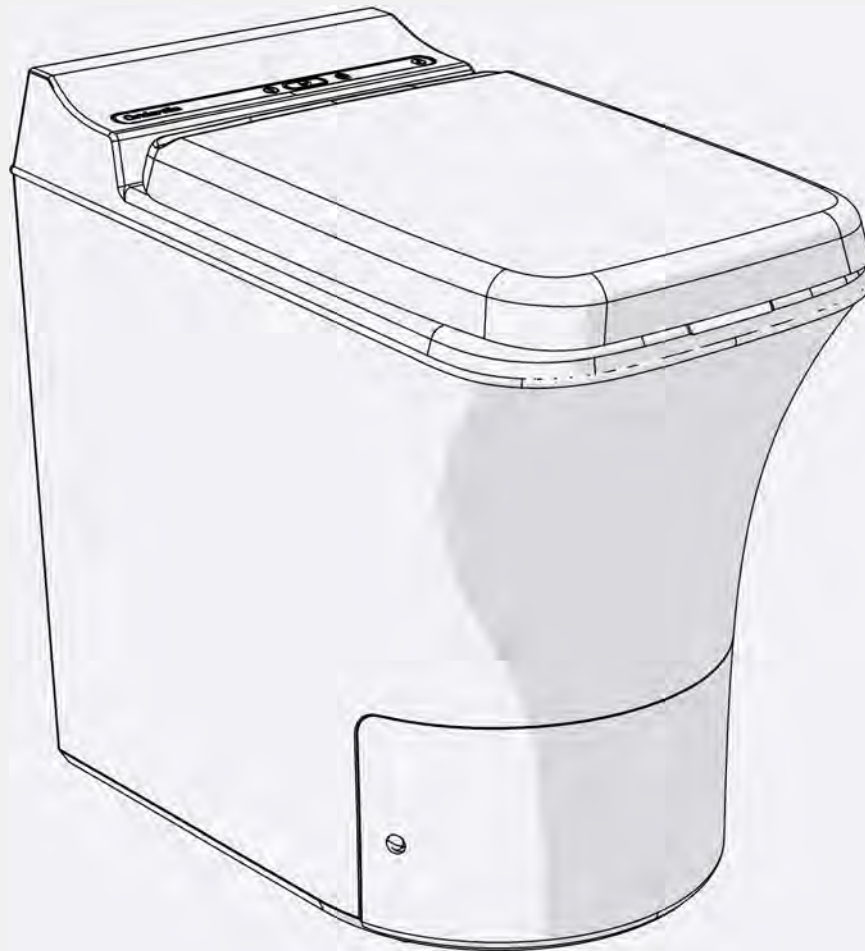

Document number: D000766
Revision number: 01
Cinderella Freedom Product Manual | 01.01.2022

CONTENTS

1. GENERAL SECTION	3
1.1 INTRODUCTION	3
1.2 APPLICATION ACCORDING TO REGULATIONS	3
1.3 OPERATING INSTRUCTIONS GUIDE	3
1.4 LIMITATION OF LIABILITY	3
1.5 LISTINGS AND CERTIFICATIONS	3
1.6 ENVIRONMENTAL REQUIREMENTS	3
1.7 GENERAL SAFETY INSTRUCTIONS	4
1.8 APPLIANCE RATING PLATE	5
1.9 CINDERELLA ONLINE	5
2. INSTALLATION SECTION	6
2.1 UNPACKING YOUR CINDERELLA INCINERATION TOILET	6
2.2 MEASUREMENT SPECIFICATIONS	6
2.3 ORIGINAL INSTALLATION PACKAGES FOR YOUR CINDERELLA TOILET	7
2.4 INSTALLATION SPECIFICATIONS	8
2.4.1 SPECIFICATIONS OF PARTS AND MATERIALS	8
2.5 INSTALLING THE CINDERELLA INCINERATION TOILET	8
2.5.1 INSTALLING THE OUTLET PIPES	9
2.5.2 INLET AIR TERMINAL	10
2.5.3 INSTALLING THE ORIGINAL CINDERELLA FLUE TERMINAL CAP	11
2.5.4 GAS INSTALLATION	11
2.6 ELECTRICAL SPECIFICATIONS AND REQUIREMENTS	12
2.7 REMOVING THE TRANSPORTATION SAFETY STRAP	12
2.8 CHECKLIST TO VERIFY COMPLETE INSTALLATION	13
2.9 PERFORMANCE TEST TO VERIFY SYSTEM FUNCTIONALITY	13
3. USER SECTION	14
3.1 INTENDED USE AND HANDLING	14
3.2 GENERAL SAFETY	14
3.3 SAFETY WHEN OPERATING WITH GAS	14
3.4 SAFE OPERATIONS	14
3.5 CINDERELLA FREEDOM SAFETY FEATURES	14
3.6 IMPORTANT USER INFORMATION	15
3.7 THE CONTROL PANEL	16
3.8 USING THE CINDERELLA FREEDOM TOILET	17
3.9 OPERATING THE FRONT COVER AND ASH CONTAINER	18
4. GENERAL MAINTENANCE INSTRUCTIONS	19
4.1 END PRODUCT CHARACTERISTICS	19
4.2 CUSTOMER MAINTENANCE	20
4.2.1 EMPTYING AND CLEANING THE ASH CONTAINER	20
4.2.2 STEAM-CLEANING THE CATALYTIC CONVERTER	20
4.2.3 CLEANING THE BOWL	21
4.2.4 INSPECTING AND VACUUM CLEANING THE CATALYTIC CONVERTER	22
4.2.5 CLEANING THE APPLIANCE FLUE TERMINAL	22
4.2.6 RINSING THE CATALYTIC CONVERTER WITH HOT WATER	23
5. TROUBLESHOOTING AND FAQ	24
5.1 TROUBLESHOOTING TABLE	25
6. REPAIRS AND SPARE PARTS	26
6.1 SPARE PARTS LIST	26
6.2 WIRING DIAGRAM	26
7. WARRANTY	27

1. GENERAL SECTION

1.1 INTRODUCTION

It is essential to ensure proper ventilation in accordance with the guidelines in this manual to guarantee the functionality of your new Cinderella toilet. Improper installation may cause malfunction, wear and/or odours and will void the warranty. When installing the appliance, the technical and administrative regulations in the country in which it is installed must be adhered to.

1.2 APPLICATION ACCORDING TO REGULATIONS

This appliance is designed to incinerate bodily waste products and small sanitary products such as toilet paper and non-alcohol baby or face wipes.

This appliance must not be installed in a mobile or portable installation such as a mobile home, recreational vehicle or caravan.

1.3 OPERATING INSTRUCTIONS GUIDE

Please read this instruction manual carefully before installation and first use. Store these instructions in a safe place so you can refer to them when required. If you pass on the product to someone else, hand over this instruction manual along with it.

These instructions provide you with the necessary guidance for proper installation, handling and maintenance of the product. It is important that both the installer and the user familiarise themselves with the instructions given in this manual. The manual also contains information on professional maintenance and any necessary information for service and repairs.

A digital version of this document and further information can be found at www.cinderellaeco.com

1.4 LIMITATION OF LIABILITY

The manufacturer accepts no liability for damage in the following cases:

- Faulty installation
- Damage to the product resulting from incorrect connection voltage
- Alterations to the product without express permission from the manufacturer
- Use for purposes other than those described in the operating manual
- Non-observation of the operating and maintenance instructions
- Application not in accordance with the regulations or provisions
- Use of non-original bowl liners and spare parts

1.5 LISTINGS AND CERTIFICATIONS

The Cinderella Freedom has been extensively tested by DBI and SLG in accordance with the European standard for gas safety and electromagnetic compatibility.

1.6 ENVIRONMENTAL REQUIREMENTS

- Ambient temperature range: -20 to +40 °C
- Operating altitude: Tested to 1,500 m



CAUTION!

When the Cinderella toilet is installed, the minimum clearance to any combustible construction must be 50 mm from the sides and 50 mm from the rear.

1.7 GENERAL SAFETY INSTRUCTIONS



DANGER!

Safety instruction: Failure to observe this instruction could cause fatal or serious injury.



WARNING!

Safety instruction: Failure to observe this instruction could lead to injury.



CAUTION!

Failure to observe this instruction could cause material damage and impair the function of the product.



NOTE!

Supplementary information for operating the product.



DANGER!

- Do not spray aerosols in the vicinity of this appliance while it is in operation.
- Do not use or store flammable materials in or near this appliance.
- Do not place articles on or against this appliance.
- Do not modify this appliance.



- Do not operate the incineration toilet if it is visibly damaged.
- If the DC power cable for this toilet is damaged, it must be replaced by the manufacturer, customer service or a similarly qualified person in order to prevent safety hazards.
- Never use a naked flame to check the toilet gas connections for any leakage.
- This toilet may only be repaired by qualified personnel. Inadequate repairs may cause serious hazards.
- Only use LPG gas.
- Only operate the toilet with the pressure shown on the type plate on the back of the toilet.



WARNING!





- Danger of crushing! Do not place your hand on the hinge or underneath the toilet seat while open, as there is no soft-close function on the lid and seat.
- Do not empty the ash container when hot.
- Before activating, ensure that the power supply line and plug are dry.



- During transport, only hold the toilet by the toilet shell. Never hold the toilet by the gas connection, power cord, front cover, lid or seat or exhaust outlet.
- Check that the voltage specification on the type plate is the same as that of the energy supply.
- Only use power cables with a suitable cross-section.
- Danger of overheating! Always ensure sufficient ventilation so that the heat and emissions generated during incineration can dissipate from the flue pipe. Ensure proper air flow for the system. Always ensure sufficient ventilation into the toilet.
- Make sure that the toilet is sufficiently far away from walls or other objects so that air can circulate.

1.8 APPLIANCE RATING PLATE

The appliance rating plate can be found on the back plate of the incineration toilet. From this plate you can read the model identification, serial number, toilet ratings and support detail. You will need these details whenever you contact the customer service centre or when ordering spare parts.

<p>MANUFACTURER</p>  <p>Cinderella Incineration Toilets</p> <p>CINDERELLA ECO GROUP AS Sjøvikvegen 67, 6475 Midsund, NORWAY For sales and support call +4777711500 or visit our web www.cinderellaeco.com</p> <p>CINDERELLA FREEDOM MODEL: PM02CS03EU SERIAL:</p>	<p>Appliance Specifications</p> <p>VOLTAGE..... 12V DC CURRENT 4 A GAS:..... PROPANE FAN BLOWER:..... 12V DC GAS SUPPLY PRESSURE: 30 mBar CAPACITY..... 3-4 PEOPLE PR. HOUR CONNECTED LOAD 425 G/H EFFECT..... 2.86 kW EXHAUST SYSTEM CONSTRUCTION -B22 DEVICE CATEGORY I3 B/P YEAR OF MANUFACTURING..... 2021 DESIGNED FOR..... HOME/CABINS, SANITATION WELFARE UNIT</p>	    <p>For information on how to claim warranty, support and recycle our product visit www.cinderellaeco.com</p>
--	---	---

1.9 CINDERELLA ONLINE



REGISTER WITH “MY CINDERELLA”

When you register your toilet in “My Cinderella”, you will receive relevant information about our products and available support systems, as well as special offers specifically tailored to your toilet model. In the event of theft, registered toilets will be in our manufacturer database.

Online Troubleshooter

A complete guideline to your toilet, providing useful advice and user improvements, enabling you to solve the most common issues on your own, without having to call for assistance.

Easy access to information

You can download product documentation from our online documentation centre, where you will find product manuals, service manuals and a Disassembly of Waste Electrical and Electronic Equipment (WEEE) manual.

Service and spare parts

Select country of origin and receive a list of local dealers where you can obtain service and spare parts.

2. INSTALLATION SECTION

2.1 UNPACKING YOUR CINDERELLA INCINERATION TOILET

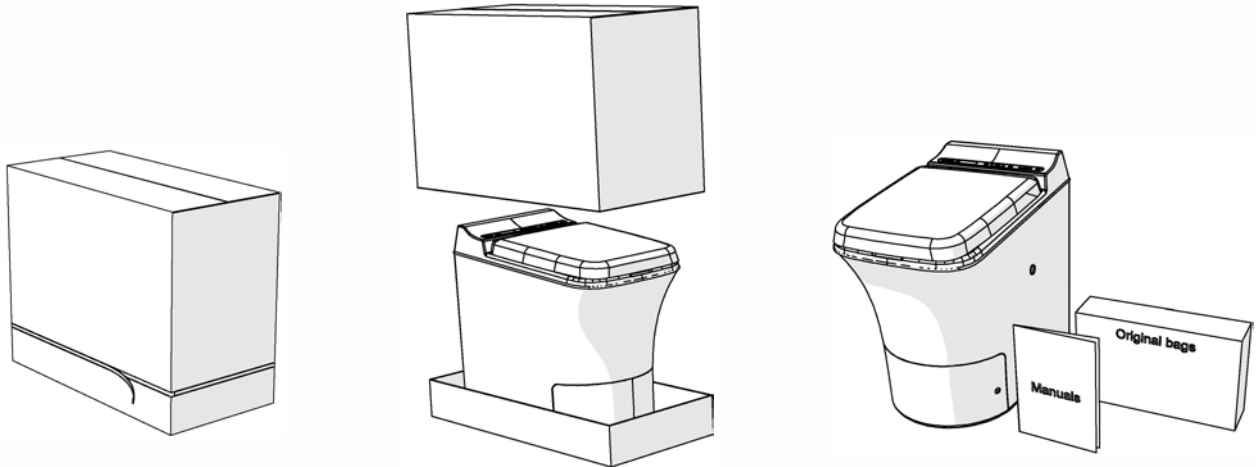

NOTE!

When unpacking the Cinderella toilet, use the pre-fixed strip on the bottom of the box. Release the strip all around the box and lift up the box.

INCLUDED ITEMS	QTY
Cinderella PM02CS03	1
Bowl liners	1
Product manual	1

2.2 MEASUREMENT SPECIFICATIONS

Height	600 mm
Seated height	540 mm
Width	390 mm

Depth	590 mm
Height centre outlet	415 mm

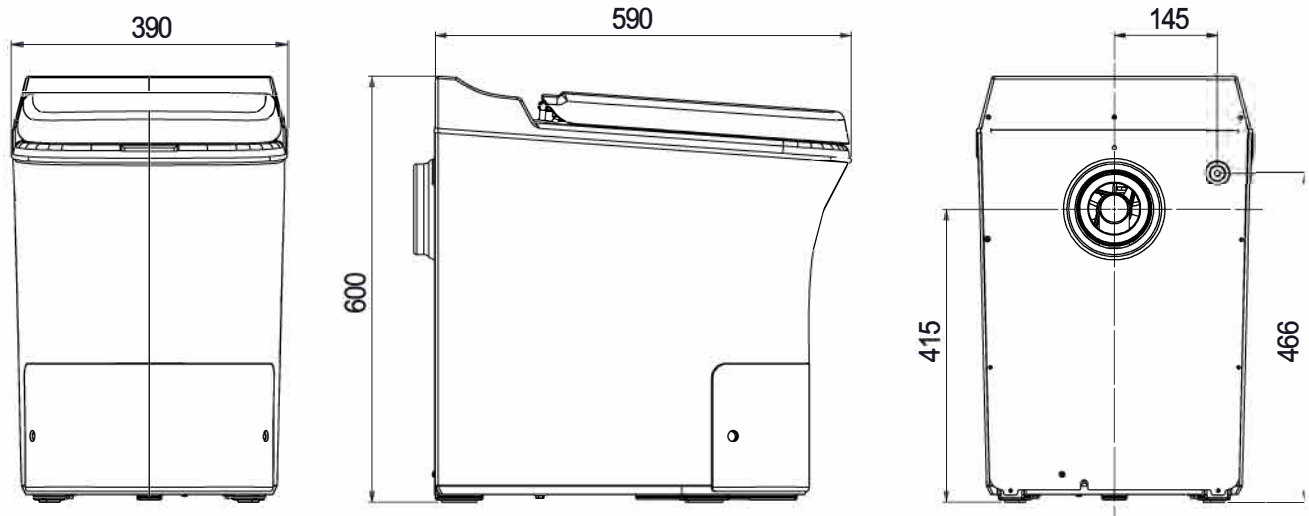

2.3 ORIGINAL INSTALLATION PACKAGES FOR YOUR CINDERELLA TOILET

Cinderella Original Installation Kit: We strongly recommend the use of the “Cinderella Original Installation Kit” when installing your appliance. This complete set includes necessary parts for an ideal installation, optimising the incinerating process and functionality of your toilet. The installation kit includes two separate boxes. Box no. 1 includes an optimised flue cowl and elbow, for increasing the system flow rate and incineration efficiency, as well as a specially designed 201 cm² air vent for optimised functionality. The kit also contains clamps to support the installation of the outlet pipes. Box no. 2 includes 7 x 110 mm UV-stabilised PP-quality pipes for installing the outlet ventilation.

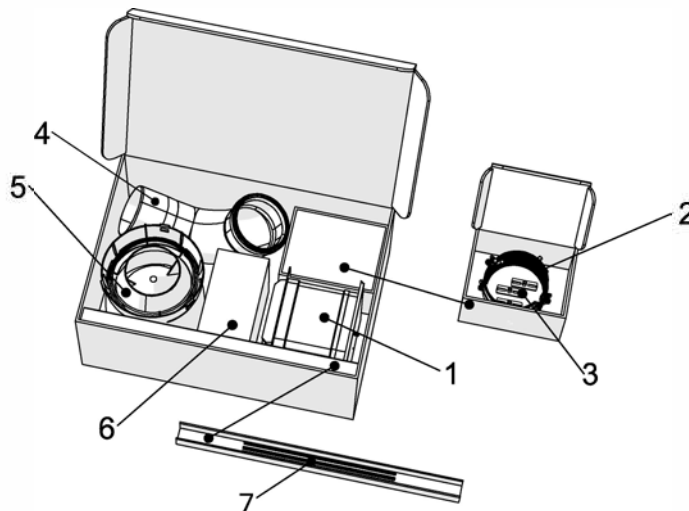
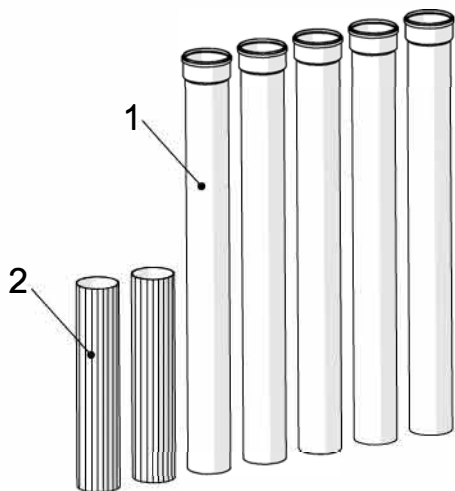

CINDERELLA ORIGINAL INSTALLATION KIT		QTY
1	Male-female 1,066 mm flue pipe	5
2	Male-male 500 mm flue pipe	2

CINDERELLA ORIGINAL INSTALLATION KIT		QTY
1	Air vent, 160 mm (201 cm ²)	1
2	Support clamp	3
3	Wall mount rod	3
4	Elbow, 87° w/drain	1
5	Flue terminal cap	1
6	Pressure regulator kit*	1
7	Threaded rod, 30 mm	3

*Norway and Sweden only



NOTE!

- This manual will further explain and demonstrate how to optimally install your toilet, based on the parts included in the Original Cinderella Installation Kit. Should you desire to install your Cinderella appliance other than with our original pipes and parts, be sure that the parts you use comply with the specifications described under section 2.4.1 “Specifications of parts and materials”.
- In order to guarantee your Cinderella incineration toilet functions properly, it is essential to ensure proper ventilation in accordance with the guidelines in this manual. Installations deviating from the manufacturer specifications or the use of non-authorised parts in the installation of the appliance will cause malfunction, wear or odours and will void the warranty.

2.4 INSTALLATION SPECIFICATIONS

2.4.1 SPECIFICATIONS OF PARTS AND MATERIALS

ITEM	SPECIFICATIONS
Ventilation pipes	Cinderella Freedom is required to be installed with 110 mm pipes with a smooth inner surface and a minimum inner diameter of 102 mm. The pipe material must be specified for temperatures over 100 °C and preferably of a PP or CPVC type. We strongly recommend using the Original Cinderella PP-quality pipes.
Elbow (outlet air)	Cinderella Freedom is required to be installed with a smooth curved elbow that minimises the restriction of the air flow. We strongly recommend using the Original Cinderella elbow, 87° w/ drain.
Flue terminal cap	Cinderella Freedom is required to be installed with a flue terminal cap that prevents intrusion of rainwater and that has a minimum restriction of the air flow. Wind fans or similar are not to be used when venting the Cinderella incineration toilet. We strongly recommend using the Original Cinderella flue terminal cap.



NOTE!

- The inside of the ventilation pipe must be smooth and not embossed or grooved.
- Never use a mesh net in the ventilation pipe, as this might restrict the airflow in the system.
- The elbow must be accessible when installed, so that the drainage pipe can be rinsed and the outlet pipe cleaned.
- Cinderella Freedom is approved for use in bathrooms/wet rooms (IP 34 classified), but water must not be splashed over the external parts of the toilet.
- The toilet must be placed on a firm and level base. Your Cinderella appliance may be installed on a heated floor.

2.5 INSTALLING THE CINDERELLA INCINERATION TOILET

It is essential to ensure proper ventilation in accordance with the guidelines in this manual to guarantee the functionality of your new Cinderella toilet. Improper installation may cause malfunction, wear or odours and will void the warranty. Read each section carefully before starting the installation of the toilet. Always make sure that the work is carried out by professionals in accordance with local regulations.



CAUTION!

- Upon installation of the appliance, the technical and administrative regulations of the country in which the toilet is installed must be adhered to. We recommend that you contact your local dealer for planning and installing your Cinderella toilet.
- Never use bends in addition to the elbow.
- If the pipe perforates the roof surface, ensure that it is in compliance with building regulations.
- Do not use any flexible ducts or pipes when installing the Cinderella toilet.
- Never connect more than one appliance to the vent.



WARNING!

Before cutting any holes, always check that in doing so you will not cut through any electrical wiring or water pipes.

2.5.1 INSTALLING THE OUTLET PIPES

DIAMETER VENT PIPE	OUTLET DIRECTION	REFERENCE	BENDS	MAXIMUM PIPE LENGTH
110 mm	Horizontal flue pipe	C	(Not allowed)	1.0 m
110 mm	Vertical flue pipe	A	None	5.0 m

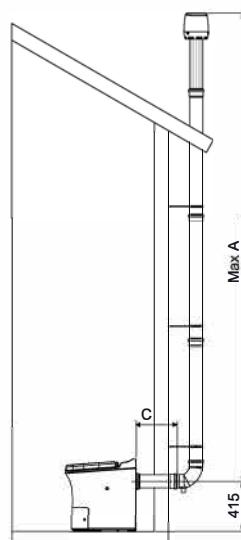
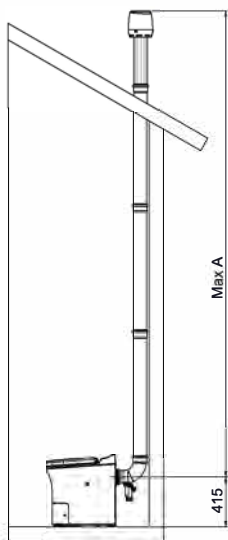

NOTE!
The centre of the appliance flue terminal is 415 mm from the floor level.

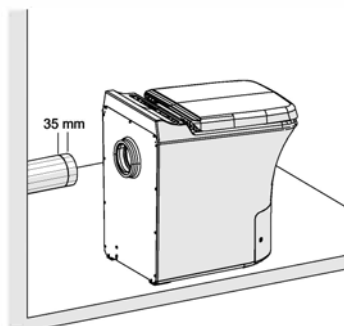

NOTE!
When adjusting the pipe length, please note that the pipe will enter 35 mm into the appliance flue terminal, and this will have to be calculated into the planning of your installation.

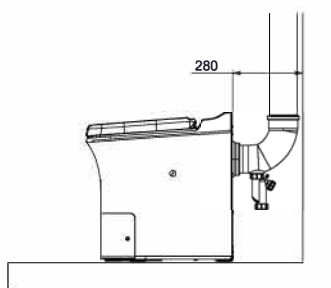

NOTE!
When installing the pipe vertically, straight up from the appliance, please note that the minimum distance from the wall to the toilet must be 280 mm.

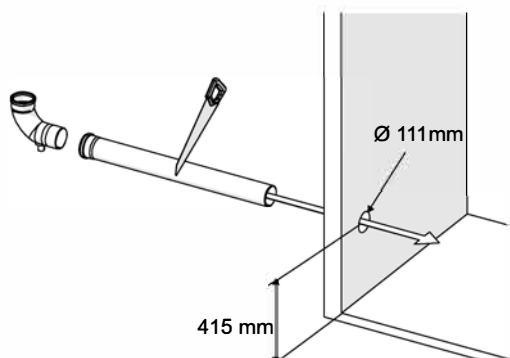

NOTE!
The Original Cinderella Installation Kit includes 5 x 1,066 mm pipes to be used on the outlet installation. The pipes are delivered with socket and gasket for simple installation. When installing the pipe through an outer wall, you will have to feed the pipe through from the outside.

**NOTE!**

- The pipe must always be installed vertically above the roof and extend at least 600 mm above the roof surface. If the outlet air pipe is to be enclosed (e.g. using metal siding), make sure that the end of the pipe extends at least 400 mm above the enclosure.
- If installing where snow is likely to accumulate, it may be necessary to extend the pipe further, and to secure accordingly. Keep in mind not to extend beyond the maximum allowed pipe length.

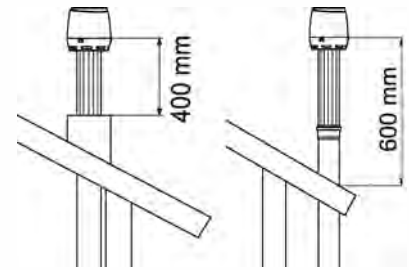
**NOTE!**

Cinderella supplies a specially designed “siphon” that fits onto the elbow provided in the installation kit. This item can be purchased as an accessory from any Cinderella dealer. If installation is done from inside, you will need to connect the siphon to the elbow piece to prevent condensation and rainwater from draining onto the floor. Failure to collect the condensation and empty it regularly may result in damage to the floor.

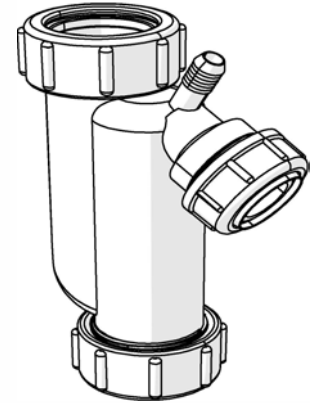
**2.5.2 INLET AIR TERMINAL**

An inlet air vent in accordance with manufacturer specifications is required to ensure adequate air circulation and the oxygen required for proper incineration. The Cinderella Original Installation Kit includes a specially designed air vent designed for optimal flow and increased product efficiency. The air inlet vent should preferably be installed as close to the Cinderella toilet as possible, to ensure a good air supply to the toilet and reduce the environmental impact in the toilet room. It is important that there are no other air-dependent installations used at the same time as the toilet, e.g. an extractor fan or fireplace. The Cinderella Freedom toilet draws air mainly from the underside of the toilet. It is therefore possible to have the air intake underneath the toilet. This allows you to insulate the air as much as possible in the toilet and minimise the environmental impact in the toilet room.

**NOTE!**

- The inlet vent’s minimum dimensions must be 160 mm (diameter)/201 cm².
- The vent must be open at all times when using the appliance. Remember to clean the vent at regular intervals.
- Make sure that there is no conflict between the toilet’s air supply and other installations, such as a fireplace or extractor fan.
- Do not use a separate ventilation fan or similar to extract air from the room where the toilet is installed when using the Cinderella Freedom toilet.
- If you have open ventilation under the toilet, it may be advisable to use a mesh over the hole to prevent insects and vermin from entering the toilet. Make sure that the mesh is not too fine – a minimum of 5 mm – as smaller mesh will impede the air flow.

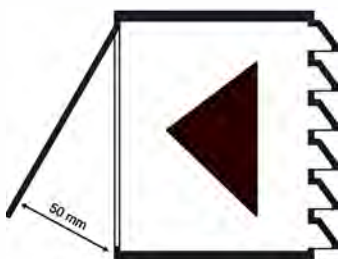
**NOTE!**

If the installed air vent has an adjustable opening, always make sure to leave it open by a minimum of 75 mm (two clicks) when operating the toilet.

2.5.3 INSTALLING THE ORIGINAL CINDERELLA FLUE TERMINAL CAP



NOTE!

The Cinderella Original installation Kit includes a flue terminal cap that is designed for optimal flow and increased product efficiency. This cap consists of two parts, where the base section can be fixed to the pipes with stainless screws or glue for easy connection and removal for maintenance of the ventilation pipes. Use the 500 mm pipe included in the Cinderella installation kit as the last section of the ventilation pipe. This will utilise the connection of the flue terminal cap.

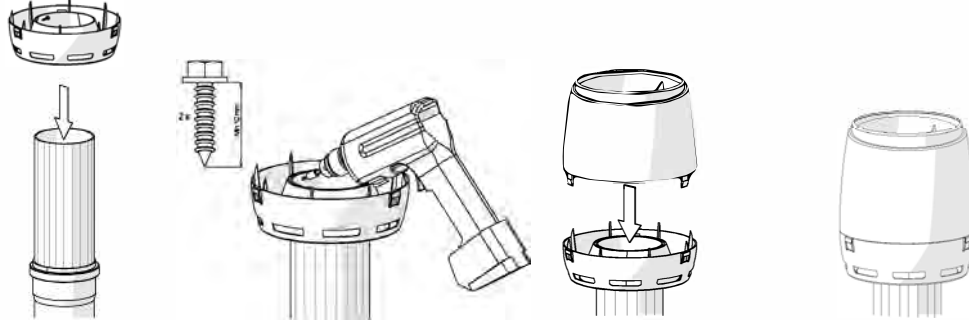

2.5.4 GAS INSTALLATION

When connecting gas to the toilet, make sure to use the appropriate gas regulator for your area. The connection type on the appliance is ¼" NTP.



WARNING!

- Only operate the toilet at the pressure shown on the type plate on the back of the toilet.
- Only operate the toilet with the type of gas shown on the type plate on the back of the toilet.
- The toilet is suitable only for indoor installation.



SPECIFICATIONS	VALUE	NOTES
Fuel consumption	160-190 g	Per incineration
Inlet gas pressure	30 mBar	
Gas type	LPG	
Gas connection appliance	G ¼" LH	
Orifice size	1 mm	

2.6 ELECTRICAL SPECIFICATIONS AND REQUIREMENTS

The correct voltage, frequency and amperage must be supplied to the appliance from a dedicated, earthed circuit that is protected by a properly sized circuit breaker. The proper voltage, frequency and amperage are listed in this manual, and on the product rating plate on the back of the toilet. Please note: This toilet requires a 12 V 4 A DC supply. If you need to operate it from a 240 V AC power point (GPO), please request the approved power supply from your dealer.

Power requirements	INPUT	CURRENT	FUSE
	12 V DC (11–14.4 V)	4 A	10 A
Power consumption	HIBERNATION MODE	STANDBY MODE	INCINERATING MODE
	0.005 A	0.09 A	1.3 A
Connection polarity	CROSS-SECTION	POSITIVE	NEGATIVE
	2 mm ²	Red	Black

The respective negative and positive cables of the DC connection must not be joined to one another in a camper, as this can cause electrical interference and damage to electrical components. The 12 V supply must be connected on its own circuit direct to the battery, with a 10 A fuse at the start of the circuit. Use the 12 V wiring guide to calculate the correct cable size according to the cable length.

12 V WIRING GUIDE						
Amps	1 m	2 m	5 m	6 m	8 m	10 m
4	2 mm ²	2 mm ²	2 mm ²	4 mm ²	4 mm ²	4 mm ²

When connecting the toilet to the mains DC power, take the following into consideration:

- Make sure the cable has sufficient current rating for the expected load in the circuit, including a margin of safety.
- Make sure the cable cross-section is dimensioned for the intended cable run length, and that the cable will not cause the voltage to drop.
- Always check the polarity of the cables before connecting, as reverse polarity connection is not covered under warranty.



NOTE!

- The connection cable must be laid in such a way that it does not come into contact with sharp edges.
- Changes to the internal electrical installation or the connection cable must be performed by a professional tradesman or a similarly qualified person in order to prevent safety hazards.

2.7 REMOVING THE TRANSPORTATION SAFETY STRAP

The ash container is equipped with a safety strap that must be removed before use:

1. Remove the front cover.
2. Cut away and remove the plastic straps attaching the ash container to the steel frame.

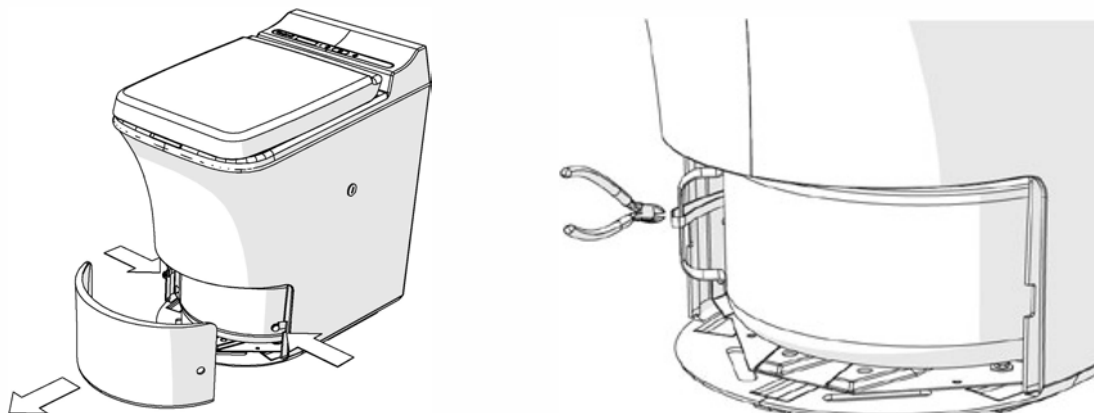

2.8 CHECKLIST TO VERIFY COMPLETE INSTALLATION

CONTROL ITEMS	CONFORMANCE
The connected voltage is in accordance with the appliance rating plate	
The connected gas pressure is in accordance with the appliance rating plate	
The appliance is installed in accordance with manufacturer specifications	
The flue pipe is installed according to manufacturer specifications	
The flue termination is no less than 600 mm from the roof surface	
Safe draining "siphon" is installed where condensation is likely to accumulate	
Flue pipe material is installed according to manufacturer specifications	
Flue cap is installed according to manufacturer specifications	
Inlet air is in accordance with manufacturer specifications	

2.9 PERFORMANCE TEST TO VERIFY SYSTEM FUNCTIONALITY

When the "Start" button is pressed, the incineration cycle will be activated. The estimated incineration time for the verification test is approximately 60–80 minutes. The yellow light will be lit when the incineration is ongoing, and the complete test should be completed without any fault indications or system interruptions. The toilet will have to cool down to the point that the fan has stopped before the ash container can be removed. The cooling phase can take from 60–90 minutes, depending on the ambient cooling temperature.

The end result should only be fine white dust. Any end results deviating from this or an incineration time exceeding 90 minutes may indicate a restriction in the flue vent or a lack of oxygen. Check that the installation is in accordance with the manufacturer specifications presented in section 2 of this manual.

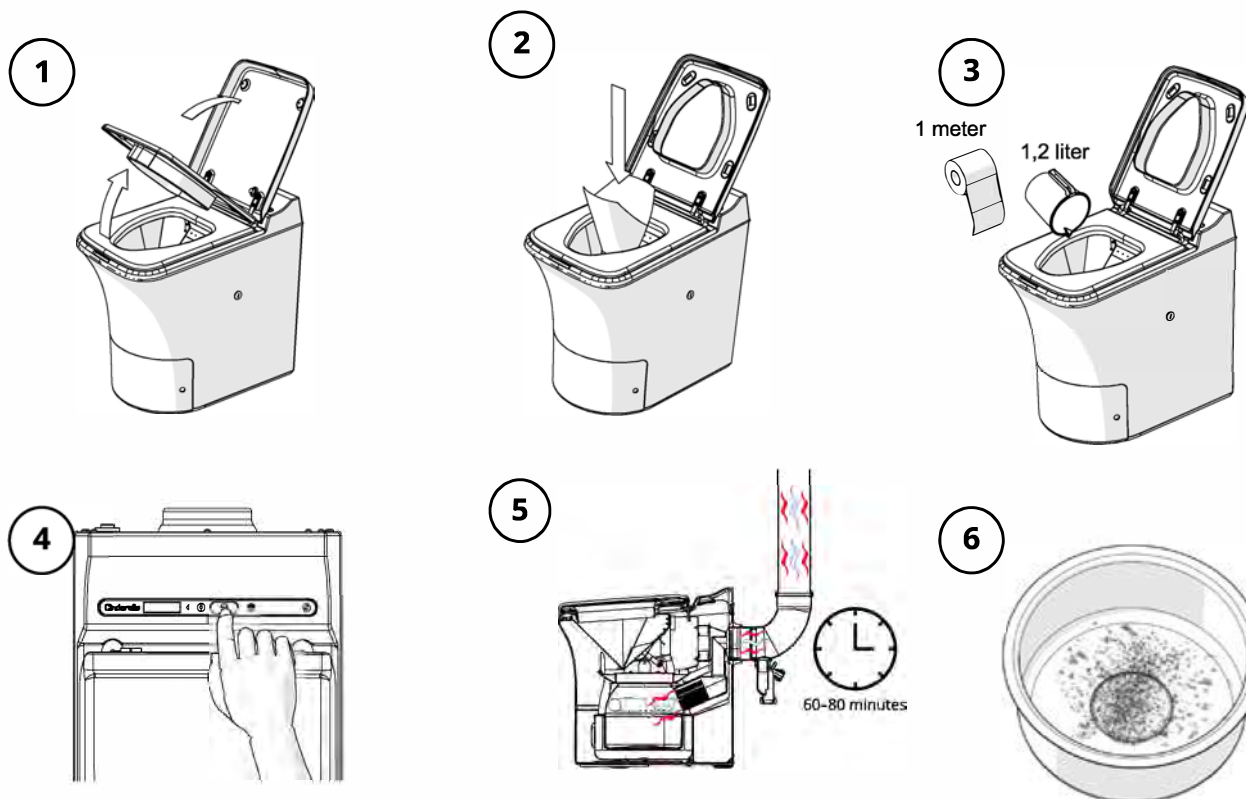

WARNING!

The ash container will get very hot while incinerating. Do not remove the front lid until the toilet has cooled completely and the fan has stopped.



NOTE!

- The performance test is designed to be performed when the toilet has not been used. Results may vary when performing this test on used toilets.

3. USER SECTION

3.1 INTENDED USE AND HANDLING

The Cinderella Freedom toilet is intended for indoor installation and use in leisure homes such as cabins, second homes, outhouses, site welfare units, boathouses and pool houses. The toilet is solely designed to incinerate bodily waste products and small sanitary products such as toilet paper, sanitary pads and non-alcohol baby, face and cleaning wipes. Using the Cinderella Freedom to incinerate other items constitutes misuse and will void your warranty.

Do not put the following items into the toilet:

- Excessive amounts of paper of any kind
- Chlorine-based cleaning agents
- Alcohol cleaning wipes
- Newspaper
- Paper towels
- Flammable liquids or materials
- Cigarette lighters
- Cigarettes or cigars
- Petrol
- Alcoholic drinks or liquors
- Alcohol or rubbing alcohol
- Nail polish remover
- Lighter fluid
- Lamp oil / kerosene
- Aerosol containers
- Glass or plastic bottles or containers etc.

3.2 GENERAL SAFETY



DANGER!

- Do not operate the incineration toilet if it is visibly damaged.
- If the connection cable for the toilet is damaged, it must be replaced by the manufacturer, customer service or a similarly qualified person in order to prevent safety hazards.
- This incineration toilet may only be repaired by qualified personnel. Unauthorised repairs can result in considerable danger or damage to the toilet.
- Cleaning and user maintenance may not be carried out by unsupervised children.
- Do not use any explosive substances or flammable cleaning agents when maintaining the toilet.

3.3 SAFETY WHEN OPERATING WITH GAS



DANGER!

- Never use an unshielded flame to check gas-bearing parts and pipes for leakage, as this presents a risk of fire or explosion.
- In case of gas odour:
 - Close the gas supply stopcock and the valve on the cylinder.
 - Open all windows and leave the room.
 - Do not turn any electrical switches on or off.
 - Put out any naked flames.
 - Have the gas system checked by a specialist.

3.4 SAFE OPERATIONS



WARNING!

- The ash container in the toilet will become very hot when the toilet is in use. Make sure the safety cover is in place when the toilet is in use. Do not empty the ash container until the toilet has cooled completely.
- The seat does not have a soft-close function. Take care not to crush your hands or fingers when closing the seat or lid.

3.5 CINDERELLA FREEDOM SAFETY FEATURES

- The incineration process is inactive while the toilet lid is open. The incineration will not start until the seat and lid are closed.
- The hatch to the incineration chamber CANNOT remain open while the toilet is still hot (e.g. during cleaning). This is only possible when the toilet has cooled down and the fan has stopped.

- Should a ventilation problem arise and the internal temperature of the toilet increases to more than 105 °C, incineration will be interrupted and a warning message displayed. This situation requires a manual reset to ensure the ventilation issue is addressed before the toilet can be used again.
- If the ash container is improperly positioned after emptying, incineration will not start and a warning light and message will be displayed.
- If the combustion chamber hatch mechanism gets jammed or is prevented from closing properly, incineration will not start and an error message will be displayed.
- The Cinderella Freedom's smart software includes a "watchdog" function that monitors the temperature while incineration is taking place. If any deviations from the normal temperature range are detected, this will immediately result in the incineration stopping and a warning message being displayed.

3.6 IMPORTANT USER INFORMATION



NOTE!

- Always remember to place a new liner in the toilet bowl before use, one liner per visit.
- The toilet lid must always be closed when the toilet is not in use. Incineration will not start or continue until the lid has been closed.
- The incineration cycle could take up to 180 minutes from the most recent visit.
- The fan will continue to run until incineration is completed and the internal temperature of the toilet has returned to the normal range. The cooling phase can exceed 120 minutes after incineration is completed, depending on the temperature of the air provided for cooling.
- Your Cinderella toilet may be used at any point during the incineration or cooling processes. Incineration is interrupted during use. Be sure to close the lid and press "Start" at the completion of each visit.



Capacity: 4 persons

The Cinderella Freedom toilet is designed to handle up to four visits per hour. To avoid overload, more than four visits per hour is not recommended. Overloading the toilet with many visits in a short period of time, without completing an incineration cycle, can result in odours and leakage, and may damage the toilet.



Emptying frequency

The total liquid capacity of the system's waste container is 5 L. The ash container should be emptied frequently (once a week) for best operation. This ensures more efficient incineration and helps keep the catalytic converter cleaner.

If your ash container has not been removed (by weekly emptying routines), your Cinderella Freedom will display a message to empty the container after 90 incineration cycles, and will lock out further visits if not emptied after 120 visits. We recommend that you empty the toilet as often as possible to ensure better incineration efficiency and less wear of the product.

Failing to empty the ash container when full may cause damage to the toilet and void your warranty.



Preparing your toilet for a lengthy period of non-use

In cases of longer periods of non-use, the waste must be incinerated, and the ash container emptied.



Short period of increased use

Should the situation require an unusually high number of guests to use the toilet for a short period of time, please follow these tips:

1. Empty the ash container completely before guests arrive.
2. Preheat the toilet before use by opening and closing the lid then pressing the "Start" button.
3. Ensure guests are instructed to use a bowl liner and press "Start" after every visit.
4. Check regularly to ensure the toilet lid is closed and the yellow incineration light is still lit.
5. You may need to run an extra incineration cycle or two before emptying the ash container to ensure that the waste has been fully incinerated.

3.7 THE CONTROL PANEL

The control panel is equipped with a combination of light, sound and display messages that will give the best possible user experience. There are a number of light and sound combinations that will tell the user about the status of the system. It is important that all users familiarise themselves thoroughly with these signals before use. An overview of all the light and sound signals can be found in the troubleshooting table in section 5.1.



NOTE!

- A green light indicates that the toilet is connected to the power supply. When only the green light is lit, the toilet is in standby and ready for use.
- A yellow light indicates an ongoing incineration process and will light constantly while the toilet is in incineration mode.
- A red light indicates interruption and will alert the user that the toilet is no longer incinerating or in standby.

Standby

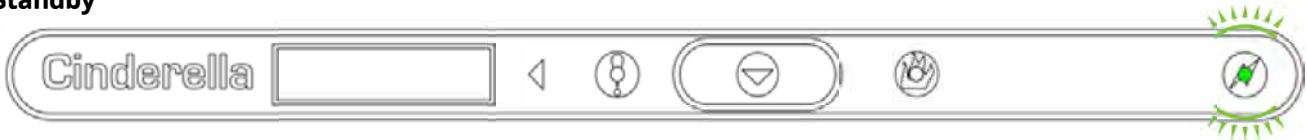

Incineration mode

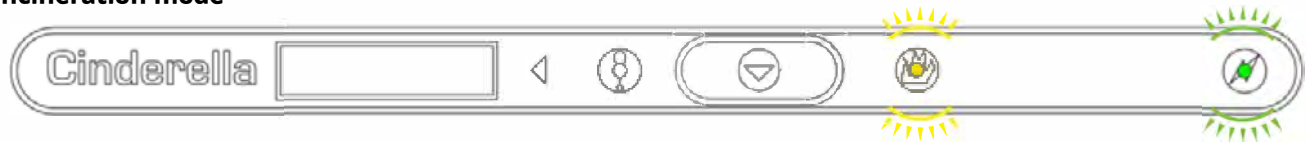

System interrupted



Selecting your language

Hold down the “Select language” button for three seconds until “Language” is displayed on the first text line. The current language will be displayed on the second line. Push the “Select language” button repeatedly until the desired language is displayed. The new language will automatically be saved a few seconds after you have chosen your language, and the toilet will resume operation.

“Select language” button

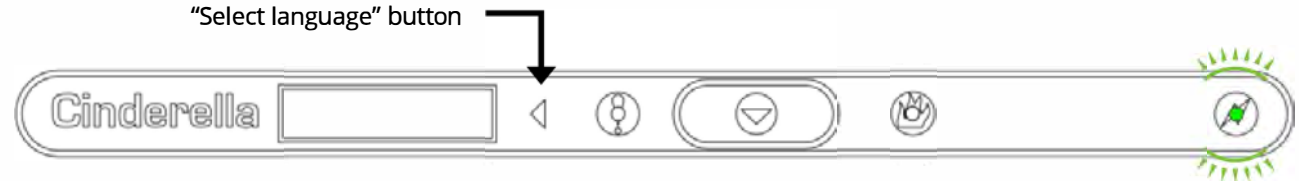

Emptying indicator

Your Cinderella Freedom will indicate when it is time to empty the ash container. The display will read “EMPTY THE ASH CONTAINER” and you will hear three short beeps when the toilet lid is opened. If not emptied within a certain amount of uses, the toilet will lock down. At this point the yellow, red and green lights are constantly lit and the display will read “TOILET LOCKED CONTAINER FULL”. You will hear three short beeps every ten seconds until the ash container is emptied.

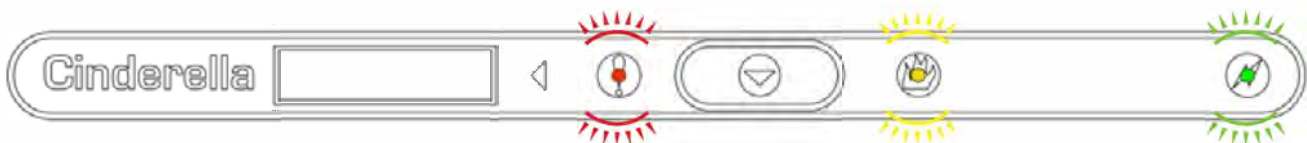

3.8 USING THE CINDERELLA FREEDOM TOILET

1



1. Check that the green light on the control panel is lit, indicating the unit is powered and ready for use.

2

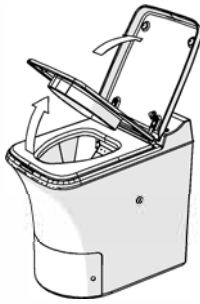

2. Lift the toilet lid and seat. A red light starts flashing. The ventilation fan starts.

3



3. Place a bowl liner in the bowl. Use a new bowl liner for every visit.

4

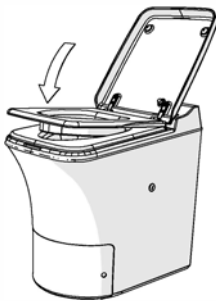

4. Lower the seat. The toilet is ready for use.

5

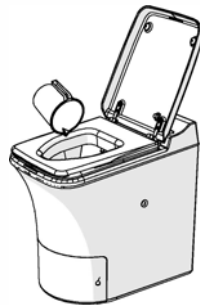

5. Use the toilet as usual. If little waste is produced, it may be helpful to pour some water into the bowl to add weight.

6



6. Close the toilet lid.

7

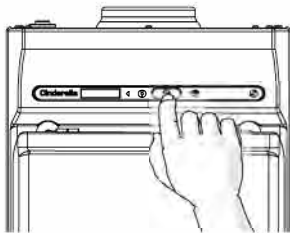

7. Push the "Start" button to drop the bowl liner and its contents into the incineration chamber. Incineration begins as soon as the hatch is closed. The toilet is now ready for the next user.

8



8. A constant yellow light will display during active incineration. The toilet may be used at any point. This will temporarily interrupt incineration. Incineration time may vary based on the number of visits and amount of waste.

3.9 OPERATING THE FRONT COVER AND ASH CONTAINER



WARNING!

Only operate the ash container when the toilet is cooled and in standby mode.



NOTE!

Please see the maintenance section for instructions regarding cleaning and emptying the ash container.

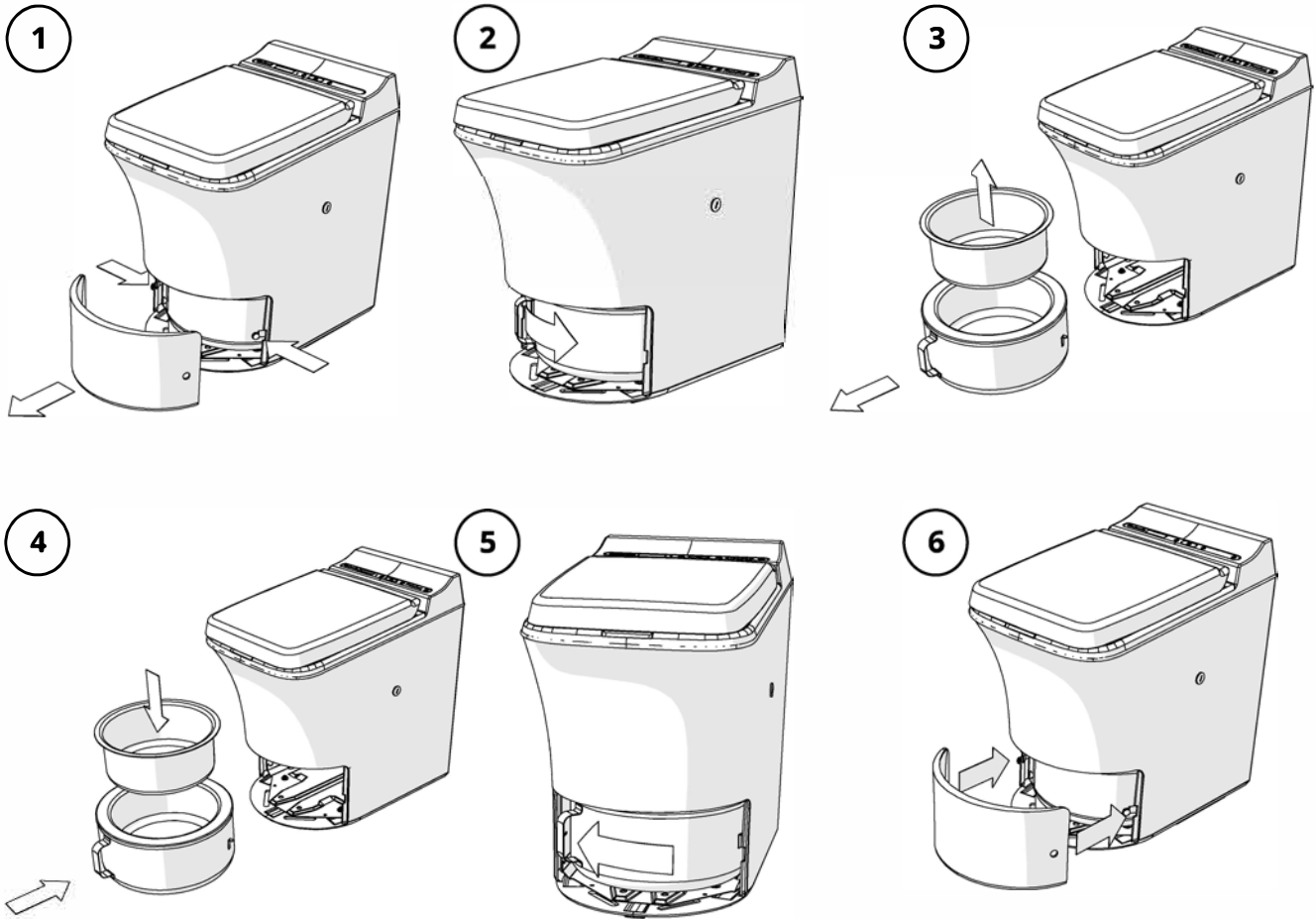

4. GENERAL MAINTENANCE INSTRUCTIONS

This manual includes both customer maintenance and the maintenance to be performed by professionals in accordance with the necessary expertise and authorisations.

A smooth-running air circulation system is critical to keep your toilet functioning properly. Particles generated during the incineration process can clog the catalyst and exhaust pipe over time, and it is important to regularly maintain these parts to ensure proper functionality.

In order to ensure optimal operation and extend the lifetime of your Cinderella Freedom appliance, you will need to set aside a little time for preventive maintenance. Good maintenance routines will give you lower operating costs and cause less wear on the product. We strongly advise our customers to perform frequent maintenance as follows:

1. Empty the toilet frequently. Do not base your use on the maximum limit of the appliance.
2. Always clean the ash container and insert when emptied (see section 4.2.1).
3. Always perform the steam cleaning after each box of bowl liners (500 uses), preferably after each emptying and washing of the ash container (see section 4.2.2).
4. Always observe the end result characteristics when emptying the toilet. Deviations in the end result may indicate the need for maintenance or service (see section 4.1).



WARNING!

Before performing maintenance, always make sure that the toilet is not in incineration mode and that the toilet is sufficiently cooled.

4.1 END PRODUCT CHARACTERISTICS

The residual waste, or “ashes”, will consist of pathological residue, salts and minerals, and will therefore often be perceived as hard and crystallised. There should be no visible signs of paper or flaky layers of unburned waste. The ashes should be a combination of white and a dark shade of grey. If there are larger deposits of black unburned waste, humidity or paper when emptying the toilet, please start an additional incineration without inserting paper or water. When the incineration is completed, empty the ash container and perform the maintenance procedures as instructed in this manual.

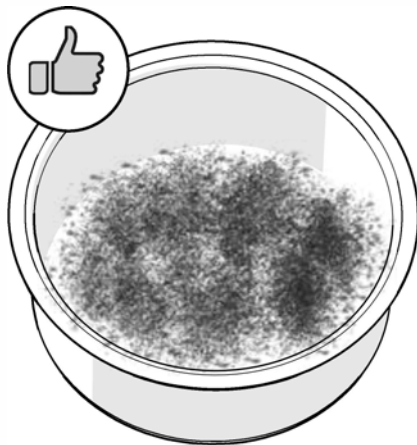

CAUTION!

- The ash is not suitable for use as fertiliser or compost. It should be disposed of in your household waste in accordance with relevant public regulations.
- The remaining ash is sterile and safe to handle when it has been incinerated to a light colour. If the ash is black and flaky or the incineration cycle was incomplete, run an extra incineration cycle to ensure that the ash has been fully incinerated. If the problem persists, see the troubleshooting section for further advice.

4.2 CUSTOMER MAINTENANCE

4.2.1 EMPTYING AND CLEANING THE ASH CONTAINER

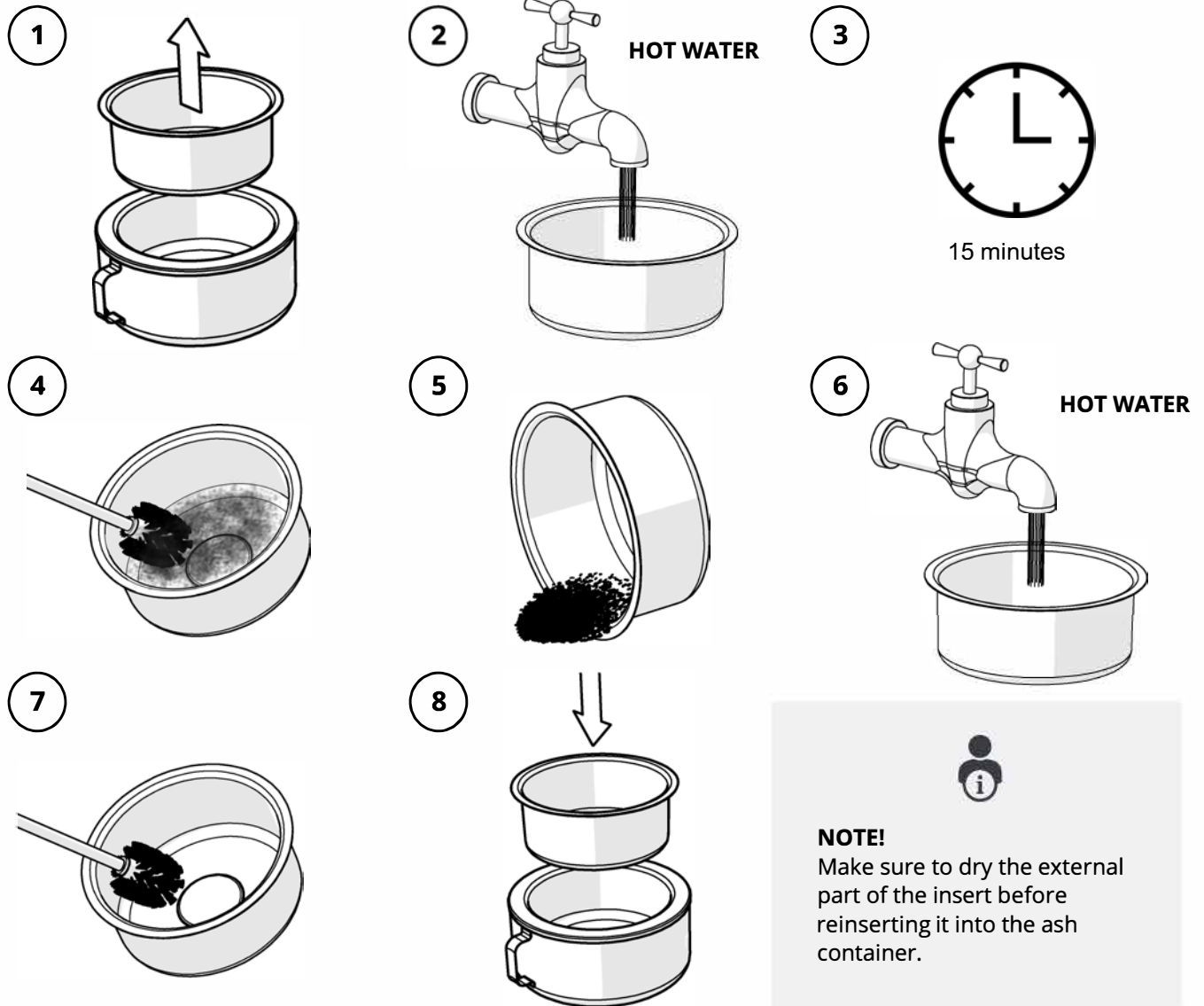

CAUTION!

Do not use any sharp tools or objects when cleaning the ash container insert, as this will damage the insert and reduce its service life.



NOTE!

- In order to preserve the functionality of your toilet in the best possible way, we recommend that you carry out the “steam cleaning” procedure in accordance with section 4.2.2 every time you empty and wash the insert. This will prevent the possible accumulation of tar and unwanted deposits in the catalytic converter and toilet exhaust system.
- When emptying the toilet, make sure that the mains power is connected. Emptying the appliance without power will not enable the system to reset the use counter.

4.2.2 STEAM-CLEANING THE CATALYTIC CONVERTER

Recommended frequency: When emptying the ash container or at least every 500 uses. To perform steam cleaning:

1. Ensure that the toilet is cold and the ash container has been emptied and cleaned (see section 4.2.1).
2. Remove the front cover and release the ash container.
3. Pour approximately 1 L of clean water into the toilet insert.

4. Insert the ash container carefully without spilling any water, and attach the front cover.
5. Lift the lid and verify that the fan starts spinning.
6. Press "Start" to begin an incineration cycle.
7. The water will start to boil and the steam will clean out any debris in the catalytic converter. This system cleaning will normally take 60-80 minutes.

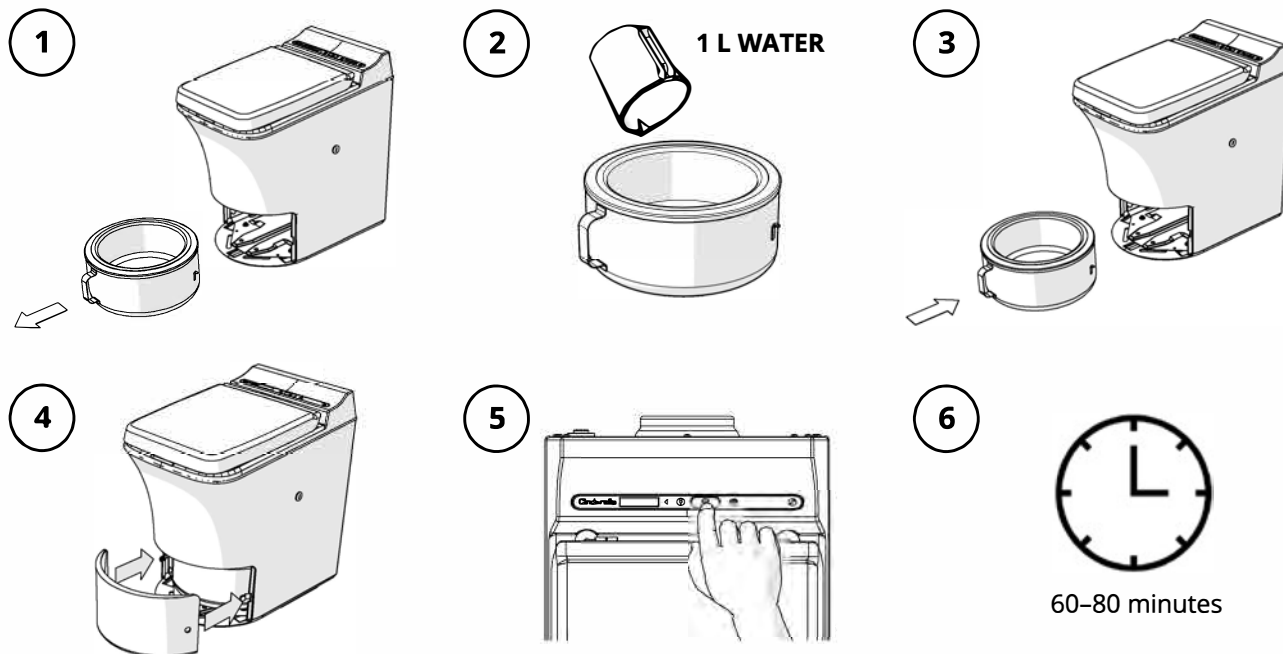

NOTE!

Do not use the toilet during the maintenance procedure, as this will impair the function of the cleaning. The toilet can be used when the toilet returns to standby mode.

4.2.3 CLEANING THE BOWL

Recommended frequency: as required for cleanliness and when emptying the ash container.

To clean the bowl:

1. Open the toilet lid.
2. Press and hold the "Start" button for three seconds to open the hatch to the washing position.
3. Use moist paper, water and a mild cleaning agent as required. Close the lid and start the incineration.

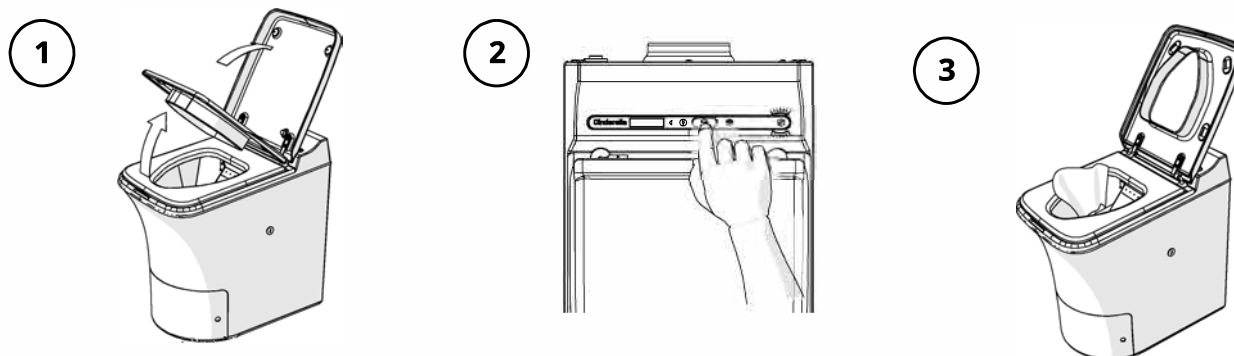

DANGER!

Do not use flammable cleaning agents to clean the bowl. Some metal edges may be sharp. The toilet needs to be cooled and in standby mode before cleaning the bowl.



CAUTION!

Do not use chlorine-based cleaning agents to clean the bowl. Chlorine is extremely harmful for the catalytic converter and if put into the toilet it may cause the catalyst to malfunction.

4.2.4 INSPECTING AND VACUUM CLEANING THE CATALYTIC CONVERTER

Recommended frequency: Every 500 uses.

The catalyst is the primary air duct between the incineration chamber and the appliance flue terminal. Any accumulations of particles in the catalytic converter will reduce the flow rate and the toilet efficiency. It is therefore important to ensure that the catalytic converter is open at all times. Any changes in incineration time and/or incineration efficiency may be due to dense catalytic conversion. The best method to easily clean the catalyst is to perform "steam cleaning" as described in section 4.2.2. You can also inspect the front of the catalyst by removing the ash container and illuminating the combustion chamber from the inside. Any particles and accumulations can be removed using a vacuum cleaner.

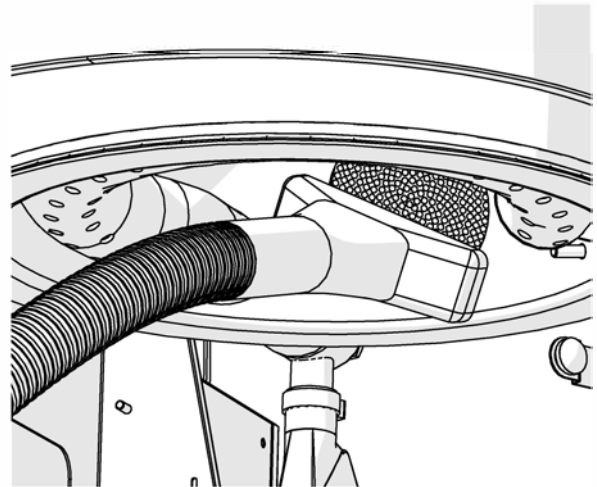
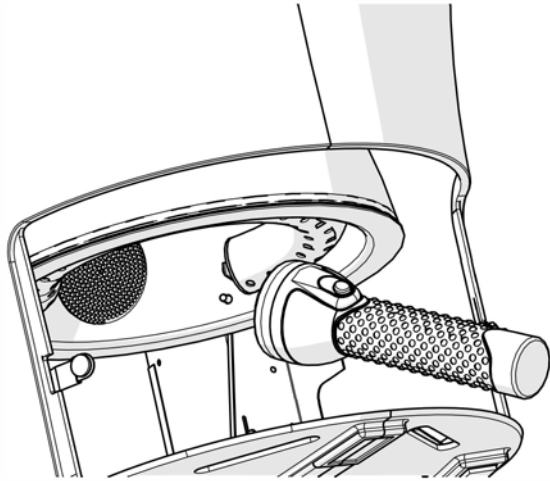

NOTE!

Clear signs of corrosion or deformity of the catalytic converter will indicate that the catalytic converter must be replaced. Contact your local service provider to arrange for service.

4.2.5 CLEANING THE APPLIANCE FLUE TERMINAL

Recommended frequency: at least every 500 uses.

1. The appliance will have to be disconnected from the flue pipe and power source.
2. Clean the flue terminal with a flexible brush. It is important that you clean both the exhaust pipe and surrounding venturi all the way back to the fan blades to get sufficient air flow.
3. Remove the ash container and clean out any debris in the container.
4. Use a vacuum cleaner to extract the remaining debris in the exhaust pipe and catalytic converter.
5. Reconnect the appliance to the flue pipe and power supply.
6. Install the ash container and front cover.
7. It is recommended that you perform a steam cleaning as described in section 4.2.2 after performing the flue terminal maintenance.

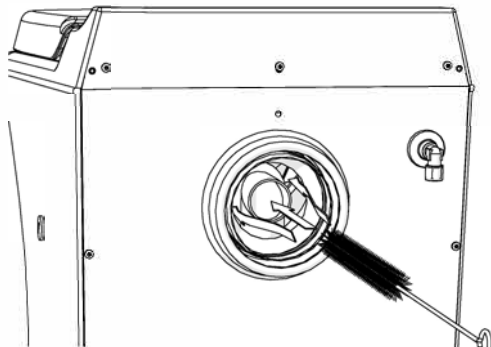

CLEAN EXHAUST AND VENTURI

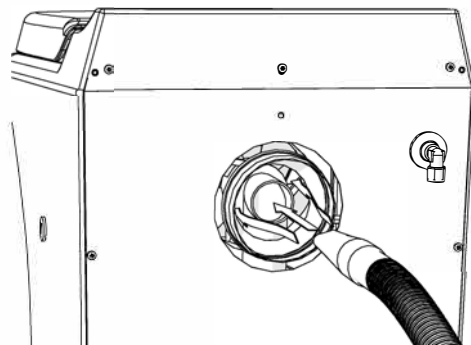

VACUUM EXHAUST AND VENTURI

4.2.6 RINSING THE CATALYTIC CONVERTER WITH HOT WATER

Rinsing the catalytic converter with water may be necessary in situations where steam cleaning does not remove the particles or bad odours. This procedure requires heavy lifting and a facility where spillage of water is acceptable. Make sure to perform steps 1–4 in the “Cleaning the flue terminal” procedure and follow the steps as follows.

1. Place the toilet where it is OK to spill water, e.g. where there is a suitable drain, outside or in a bath. Use the specially designed Cinderella funnel, or a funnel that fits in the exhaust pipe. Tilt the toilet forward and pour 2–3 L of hot water through the exhaust pipe and catalyst. The excess water should be clean at the end of the rinsing process. If necessary, use more water to properly clean the system.
2. Repeat step 1 4–5 times until the water is clean and no crystals or other obstructions can be spotted when inspecting the catalyst (see section 4.2.4).
3. Reconnect the appliance to the flue pipe and power supply.
4. Install the ash container and front cover.
5. Perform the performance test as described in section 2.8.

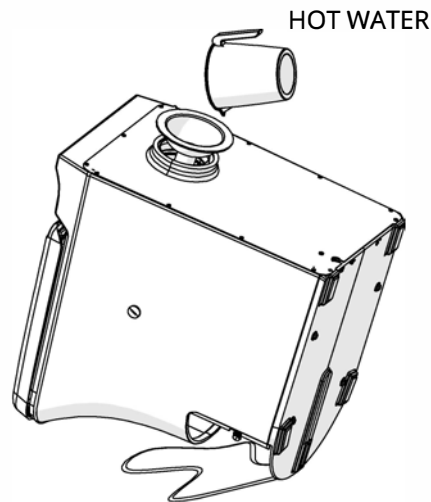

NOTE!

Before disconnecting the appliance and rinsing the system with hot water, inspect the catalytic converter and perform steam cleaning in accordance with section 4.2.2. If the catalytic converter is still clogged, or odour is still noticeable when incinerating, perform the system rinsing in accordance with section 4.2.6.



CAUTION!

The front of the outer shell is thin and should therefore not be allowed to carry the entire weight of the toilet. Tilt the appliance gently, and make sure that the toilet is placed in such a position as to protect the toilet shell. It is advised that two people perform this operation together, one holding the toilet while the other rinses the catalytic converter.

5. TROUBLESHOOTING AND FAQ



WARNING!

Service must be performed in accordance with all state, municipal and local codes. If you are unsure of the regulations in your area, please contact your nearest dealer or service representative for further instructions. The power should be disconnected when performing all servicing and maintenance on the toilet.

Online troubleshooter module

The sound and light signals on the toilet control panel indicate the operating status of the toilet. Downtime and faults in the toilet will be notified with various sound and light signals as described in section 5.1 in this manual. We have gathered the most common errors and problems in a online troubleshooter, so that you can easily get answers to what is wrong with your toilet, and get suggestions on how you can solve the problem yourself.

Out of gas

Failure to incinerate properly and a flashing yellow display light may indicate that the propane tank is empty and must be refilled or replaced.

Resetting the toilet system

During cleaning and troubleshooting, resetting the electronics may sometimes be helpful. You can do this by pressing the "Start" button. This will cause a short beep to sound. Hold down the button for about eight seconds until you hear a long beep, then release the button.

Error messages

When lights are flashing, you should look for the reason, and fix the problem before using the toilet. You must take immediate action in the event of any irregularities such as odours, poor incineration or system failures, in order to avoid damage and unnecessary repair costs.

Triggered bimetal thermostat

The bimetal thermostat is triggered if the internal temperature in the toilet is too high. This will normally occur if there is a lack of air flow, or restriction in the inlet or outlet section of the installation. It is therefore important that you check that the intake air is in accordance with the specifications, and that the flue vent is open and free of obstacles. Visually check the catalytic converter and perform the steam cleaning procedure in accordance with section 4.2.2. To reset the thermostat, unscrew the plastic screw on the side of the appliance, press the button and screw back in.



During a power outage

If an incineration process is ongoing during a power outage, you may experience temporary odours from inside the toilet and smoke and odours from the flue pipe outside. Since the incineration will not automatically restart when the mains power returns, you must manually start a new incineration cycle. If the power outage is expected to last for longer than two hours, it is important that you empty any waste from the toilet, as this could damage the toilet if it remains there for a longer period of time. Never use the toilet during a power outage.

Odours in the room

Odours can have several causes:

1. Failure to use a bowl liner each time the toilet is used or improper use of the liner.
2. The airflow may be blocked. Inspect the flue pipe and flue termination cap.
3. Check that the installation has been performed in accordance with the installation manual. Too much restriction in the flue pipe could cause back pressure and cause odours inside.
4. The exhaust pipe may be clogged. See section 4.3.1.
5. The catalyst may be clogged. See section 4.3.1.
6. The outlet pipe is not properly fixed to the toilet. See section 2.5.1.

Odours outside

The causes may be the same as for inside the room, or:

1. The catalyst has not reached operational temperature. When the toilet is cold it can take a few minutes before the catalyst reaches the temperature where it starts to function properly.
2. The catalyst may be corroded or deformed. Contact your servicing provider.

5.1 TROUBLESHOOTING TABLE

**NOTE!**

Cinderella has developed a digital troubleshooting module that can be found on our website. This module will work as a guide and supplement in addition to the troubleshooting table. Please visit www.cinderellaeco.com

ERROR	DISPLAY MESSAGE	RED LIGHT	YELLOW LIGHT	GREEN LIGHT	SOUND	ACTIONS
Ash container should be emptied	Empty the ash container	FLASHING alternately	FLASHING alternately	STEADY ON	3 BEEPS	1 Remove and empty the ash container * Toilet must be connected to 230 V
Ash container must be emptied. Toilet locked	Toilet locked container full	STEADY ON	STEADY ON	STEADY ON	3 BEEPS 10 SECONDS APART	1 Remove and empty the ash container * Toilet must be connected to 230 V
No power	Blank screen	OFF	OFF	OFF		1 Make sure that the toilet is connected to power, 230 V AC
Ventilation fan error	Error fan	FLASHING	OFF	FLASHING	10 BEEPS	1 Check fan for obstructions and ensure that fan is rotating properly 2 Reset toilet (hold down "Start") 3 Open lid until red light flashes, close lid and press "Start". If error persists, call support
Malfunctioning hatch mechanism	Error hatch mechanism	FLASHING	OFF	STEADY ON	10 BEEPS	1 If toilet is warm, reset toilet 2 Open lid until red light flashes, close lid and press "Start" 3 If unsuccessful, reset toilet, insert a bowl liner and pour 3 cups of water into the liner, close lid and press "Start" 4 If unsuccessful, wait until the toilet has cooled (fan stopped) 5 Restart toilet and open lid when the hatch is opening. Remove stuck items manually. If problem persists, call support
Ash container out of position	Ash container is out of position	FLASHING	FLASHING	STEADY ON	3 BEEPS	1 Adjust the position of the ash container, rotate the handle to the left side 2 Check that the stop pin on the container is intact 3 Visually check the condition of the magnet on the container. If problem persists, call support
Heating circuit interrupted	Error burner system	OFF	FLASHING	STEADY ON	CONTINUOUS BEEPS	1 Reset the toilet 2 Check bimetal thermostat on right-hand side of toilet. Unscrew grey plug and push on fuse inside with finger: do not use any sharp objects 3 If the fuse was triggered, you will hear a click. See section 5 4 If the fuse was not the problem, restart toilet and try to start toilet. Repeat a couple of times. If problem persists, call support
Toilet lid sensor is triggered	Lid is open	FLASHING	OFF	STEADY ON	NONE	1 Check the magnet situated inside the toilet lid and close lid. If problem persists, call support
Malfunctioning temperature sensor	Error temp sensor	OFF	FLASHING	FLASHING	CONTINUOUS BEEPS	1 Reset toilet 2 Open lid until red light flashes, close lid and press "Start" 3 If failure persists, call support
Unreadable / no display message	Unreadable / blank screen					1 Unplug toilet and wait 5 minutes 2 Plug in toilet and restart toilet 3 If problem persists, call support

6. REPAIRS AND SPARE PARTS

6.1 SPARE PARTS LIST

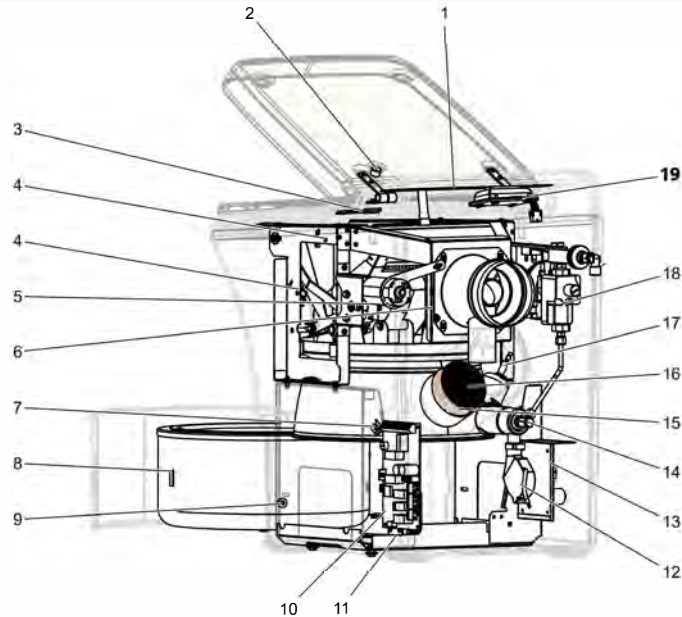

ID	PART DESCRIPTION	ART. NO
1	Control panel	100981
2	Magnet 14x10 mm	100433
3	Hall sensor w/ wire and tape L = 330 mm	100964
4	Micro switch	101127
5	Motor Nidec 12/24 V DC	101177
6	Fan axial 12 V DC 119x38 mm	100154
7	Thermocouple assembly	100831
8	Stop bracket 9x26x12 mm	100017
9	Magnet 14x7 mm	100065
10	Circuit board gas	100989

ID	PART DESCRIPTION	ART. NO
11	Hall sensor	100228
12	Fan centrifugal 51x51x15	100542
13	Ignition unit Fenwal	100424
14	Gas nozzle 8" WC propane SM	101414
15	Insulation fabric 275x90x2 mm	100163
16	Catalytic converter 90x75 mm	100528
17	Ignition electrode	100196
18	Gas control - Maxitrol CV200	101224
19	Display LED 65 x 36 x 13	100401

6.2 WIRING DIAGRAM

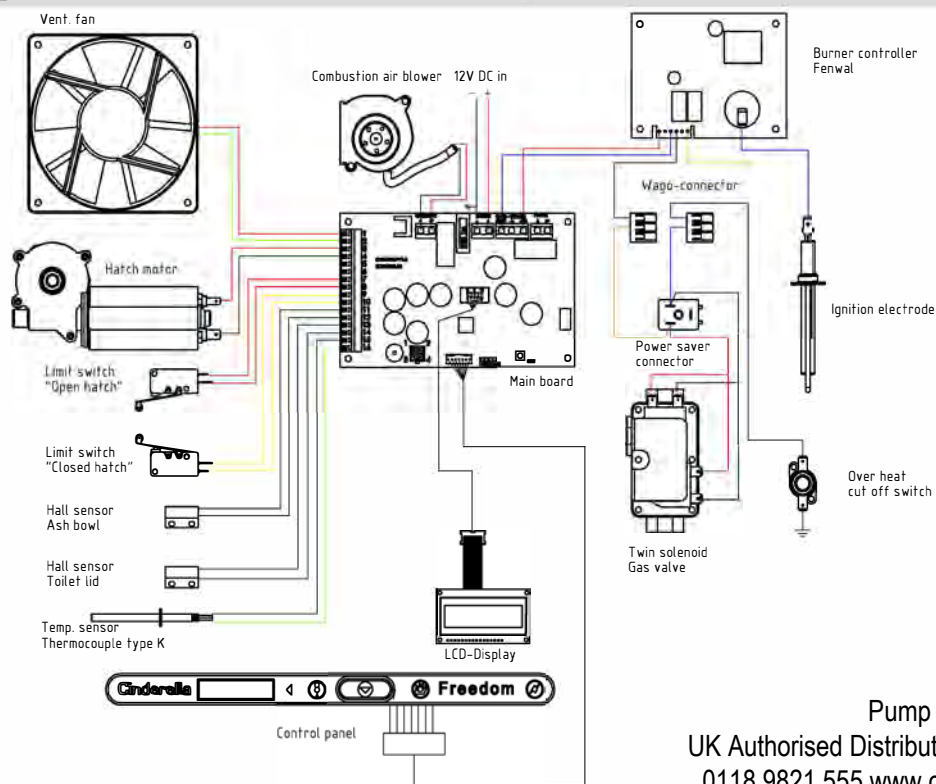

Pump Technology Ltd.
 UK Authorised Distributor for Cinderella
 0118 9821 555 www.cinderellauk.com

7. Warranty

What does this Warranty cover?

This warranty covers defects in materials or workmanship in your Cinderella Incineration Unit on the terms, for the period and subject to the exceptions set out below.

What does this Warranty not cover?

This warranty does not cover normal wear and tear or damage caused by accidents (including fire, floods, hurricanes or acts of nature), abuse, misuse, failure to follow manufacturer directions or improper maintenance. Consequential and incidental damages are not recoverable under this warranty. Cinderella Eco Group does not apply an "on-site" warranty. This means that the toilet must be transported to an Authorised Service Provider who can perform the service. If this is not possible, a transport or travel cost may be charged by the dealer.

How long does the Warranty apply?

This warranty lasts for a period of three (3) years from the original date of purchase for regular customers. Professional users are granted a one (1) year warranty.

What will Cinderella Eco Group do?

If you submit a valid claim under this warranty, Cinderella Eco Group will either repair, replace or refund the purchase price of your Cinderella Incineration Unit, at its sole discretion.

How do I arrange a service?

To arrange a service, contact your Sales dealer or an Authorised Service Provider in your country. Available service options are dependent on the country in which service is requested.

You may be required to furnish proof-of-purchase details when making a claim under this warranty. For further warranty information, please refer to our website: www.cinderellaeco.com

Cinderella Eco Group AS

Sjøvikvegen 67, NO-6475 Midsund, Norway
www.cinderellaeco.com

